



➤ POWER HOISTING

EQ SERIES ELECTRIC CHAIN HOIST

EQS SINGLE PHASE ELECTRIC CHAIN HOIST

ER2 SERIES ELECTRIC CHAIN HOIST

EDL SERIES ELECTRIC CHAIN HOIST

EDCL SERIES ELECTRIC CHAIN HOIST

EHL SERIES CHAIN AIR HOIST

ENTERTAINMENT HOISTING

RY SERIES WIRE ROPE HOIST

EQ SERIES ELECTRIC CHAIN HOIST DUAL SPEED WITH INVERTER

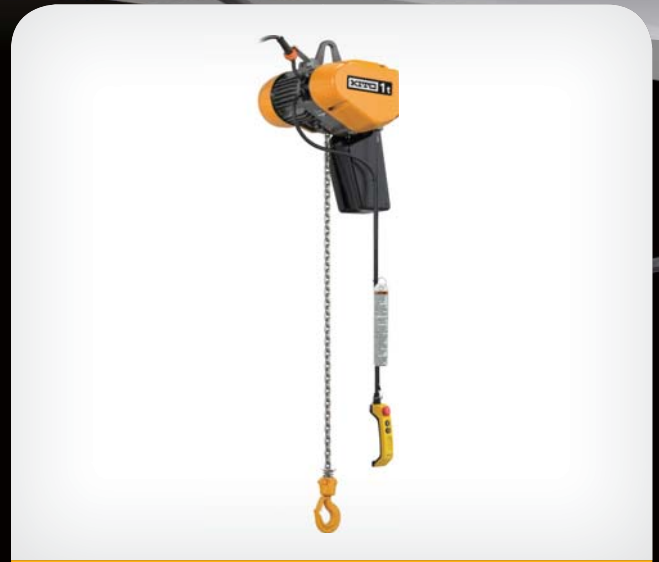

Applications

- ✓ Used in mining, construction, engineering, foundry, automotive, logistics and manufacturing industry
- ✓ Ideal for the assembly line, work station

Features

- ✓ Dual speed with inverter adjustable speed (standard speed ratio 6:1)
- ✓ Options available are 3 m and 6 m lift in 125 kg, 250 kg, 500 kg and 1 t capacities
- ✓ No-load high-speed function
- ✓ 40/20% ED duty rating
- ✓ Counter hour meter
- ✓ Triple safety mechanism consisting of electronic overload limiter, friction clutch & upper-lower limit switch (a triple-safety mechanism prevents accidents from excessive loads)
- ✓ Nickel-plated load chain
- ✓ Electronic thermal motor protection prevents the motor from overheating
- ✓ Hanging suspension: easy to assemble/disassemble

Australian Standard: AS 1418.2

Compact, light-weight EQ electric chain hoist is designed for flexibility and durability in lifting loads.

Capacity: 125kg – 1T

Options



Top hook



Push trolley



Motorized trolley

EQ Series Electric Chain Hoist

Outline

Rated capacity:	125kg-1t (Dual speed)
Voltage:	200-230V 50/60Hz, 380-460V 50/60Hz
Control voltage:	DC 24V
Duty rating:	40/20% ED
Classification:	1t: M5 (ISO/JIS), 2m (FEM), H4 (ASME) 125-500kg: M6 (ISO/JIS), 3m (FEM), H4 (ASME)
Motor insulation:	Class B
Enclosure:	Hoist body: IP55, Push button control: IP65
Suspension varieties:	Manual trolley, motorized trolley
Operating temperature:	-20 to +40°C (-4 to +104°F)
Operating humidity:	85%RH or less
Noise level:	EQ, dual speed VFD model 80dB or less (A scale: measured at 1m away from the Electric chain hoist) MR2Q 85dB or less (A scale: measured at 1m away from the Electric chain hoist)
Sound power level:	MR2Q 96dB or less (A scale)

EQ Series Electric Chain Hoist



Capacity	Part No.	Model	Standard Lift (m)	Lift Speed (m/min)	Headroom (mm)	Weight (kg)	Load Chain dia (mm) x falls	Load Chain dia Part No.
125kg	47106	EQ001IS	3	17-2.8	395	30	5.6x1	47715
250kg	47107	EQ003IS	3	10-1.7	395	30	5.6x1	47715
500kg	47108	EQ005IS	3	7.6-1.3	410	32	5.6x1	47715
1000kg	47109	EQ010IS	3	7.1-1.2	465	42	7.1x1	47716
125kg	47190	EQ001IS	6	17-2.8	395	32	5.6x1	47715
250kg	47191	EQ003IS	6	10-1.7	395	32	5.6x1	47715
500kg	47192	EQ005IS	6	7.6-1.3	410	34	5.6x1	47715
1000kg	47193	EQ010IS	6	7.1-1.2	465	46	7.1x1	47716

Motorized Trolley MR2Q



Capacity	Part No.	Model	Traverse Speed M/Min	Beam Range (mm)	Min Radius Mtr
125kg	47162	MR2Q001IS	24/4	58-153	0.8
250kg	47163	MR2Q003IS	24/4	58-153	0.8
500kg	47164	MR2Q005IS	24/4	58-153	0.8
1000kg	47160	MR2Q010IS	24/4	58-153	0.8
125kg	47167	MR2Q001IS	24/4	154-305	0.8
250kg	47168	MR2Q003IS	24/4	154-305	0.8
500kg	47170	MR2Q005IS	24/4	154-305	0.8
1000kg	47165	MR2Q010IS	24/4	154-305	0.8

KITOPWB

Premium Quality Products

For more information:

Call 1300 792 262

Visit www.kitopwb.com.au

Head Office

441 Grimshaw Street,
Bundoora, VIC 3083

Tel: 1300 792 262 Fax: 03 9467 7290

Email: vicsales@kitopwb.com.au

QLD Office

1/119 Bandarra Street,
Richlands, QLD 4077

Tel: 07 3375 1288

Email: qldsales@kitopwb.com.au

WA Office

2/11 Mallaig Way,
Canning Vale, WA 6155

Tel: 08 9256 2499

Email: wasaes@kitopwb.com.au

EQS SINGLE PHASE ELECTRIC CHAIN HOIST DUAL SPEED WITH INVERTER



Applications

- ✔ Used in mining, construction, engineering, entertainment and manufacturing industry
- ✔ Ideal for the assembly line, work station

Features

- ✔ Single Phase 240V 50Hz, it can be used where no 3-phase power is available
- ✔ Dual speed with inverter adjustable speed (standard speed ratio 6:1)
- ✔ Standard options available are 3 m and 6 m lift in 500 kg and 1 t capacities (tailored options available up to 15m)
- ✔ No-load high-speed function
- ✔ 40/20% ED duty rating
- ✔ Counter hour meter
- ✔ Triple safety mechanism consisting of electronic overload limiter, friction clutch & upper-lower limit switch (a triple-safety mechanism prevents accidents from excessive loads)
- ✔ Nickel-plated load chain
- ✔ Electronic thermal motor protection prevents the motor from overheating
- ✔ Hanging suspension: easy to assemble/disassemble

Australian Standard: AS 1418.2

Economical, light-weight and compact electric chain hoist is designed for easy portability in lifting loads.

Capacity: 500kg – 1T

Options



Top hook



Push trolley

EQS Series Electric Chain Hoist

Outline

Rated capacity:	500kg-1t (Dual speed)
Voltage:	240V 50Hz (Single phase)
Control voltage:	DC 24V
Duty rating:	40/20% ED
Classification:	1t: M5 (ISO/JIS), 2m (FEM), H4 (ASME) 500kg: M6 (ISO/JIS), 3m (FEM), H4 (ASME)
Motor insulation:	Class B
Enclosure:	Hoist body: IP55, Push button control: IP65
Suspension varieties:	Manual trolley
Operating temperature:	-20 to +40°C (-4 to +104°F)
Operating humidity:	85%RH or less
Noise level:	EQ, dual speed VFD model 80dB or less (A scale: measured at 1m away from the Electric chain hoist)

➤ EQS Series Electric Chain Hoist



Capacity	Part No.	Model	Standard Lift (m)	Lift Speed (m/min) 50Hz			Weight (kg)	Load Chain dia (mm) x falls	Load Chain dia Part No.
				High	Low	No Load High Speed			
500kg	47581	EQS005IS	3	7.6	1.3	9.9	33	5.6x1	47715
1000kg	47584	EQS010IS	3	5.1	1.2	9.2	43	7.1x1	47715
500kg	47582	EQS005IS	6	7.6	1.3	9.9	35	5.6x1	47715
1000kg	47585	EQS010IS	6	5.1	1.2	9.2	46	7.1x1	47716

*Optional lift heights available

➤ Push Trolley



Capacity	Part No.	Model	Beam Range (mm)
500kg	47508	TSP005	50-102
500kg	47493	TSP005 W20 Kit	103-203
500kg	47494	TSP005 W30 Kit	204-305
1000kg	47509	TSP010	58-127
1000kg	47438	TSP010 W20 Kit	127-203
1000kg	47439	TSP010 W30 Kit	204-305

KITOPWB

Premium Quality Products

For more information:

Call 1300 792 262

Visit www.kitopwb.com.au

Head Office

441 Grimshaw Street,
Bundoora, VIC 3083

Tel: 1300 792 262 Fax: 03 9467 7290

Email: vic-sales@kitopwb.com.au

QLD Office

1/119 Bandarra Street,
Richlands, QLD 4077

Tel: 07 3375 1288

Email: qld-sales@kitopwb.com.au

WA Office

2/11 Mallaig Way,
Canning Vale, WA 6155

Tel: 08 9256 2499

Email: wasales@kitopwb.com.au

EQ/ EQS Series Electric Chain Hoist

Suspension eye EQ EQS

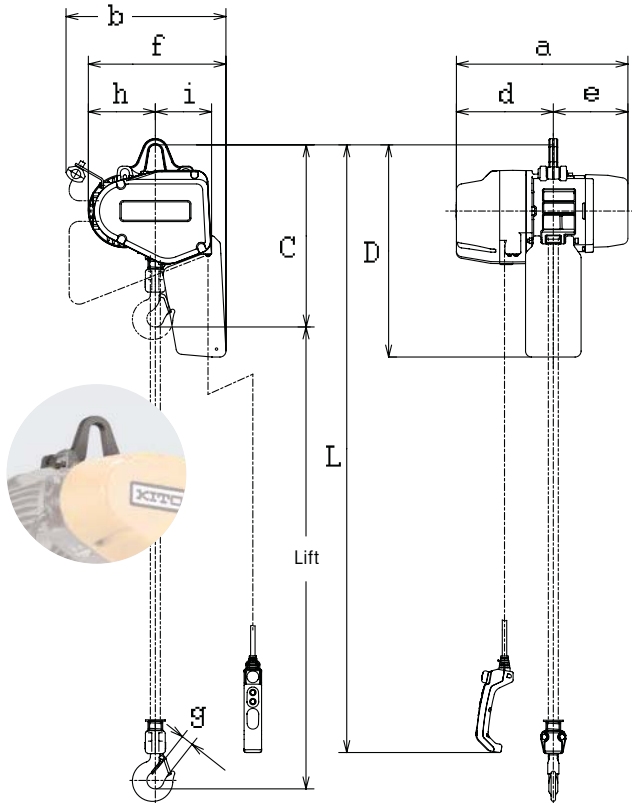

Top hook EQ EQS

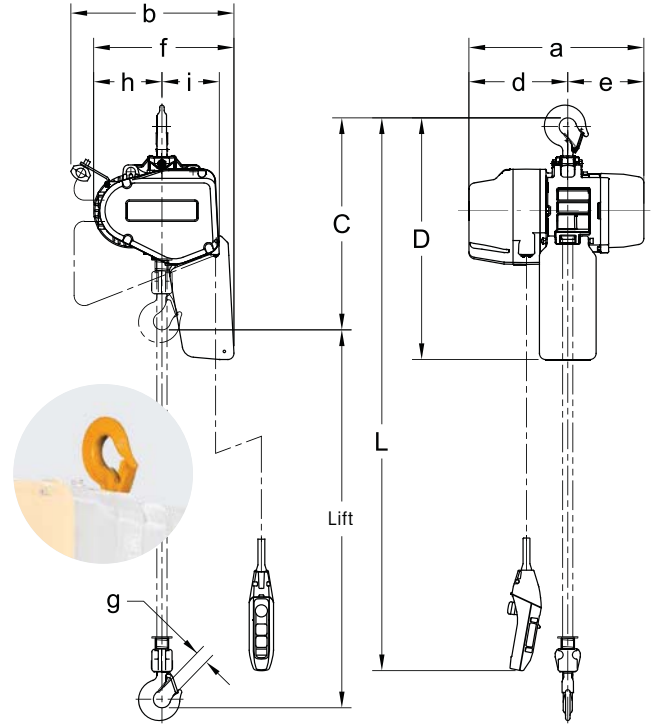

Dimensions EQ / EQS

Basic	Type	Load capacity kg	Headroom C (mm)				Dimensions (mm)							
			C top hook	C suspension eye	D top hook	D suspension eye	a	b	d	e	f	g	h	i
EQ	EQ001IS	125	440	395	533	485	417	367	230	187	298	27	137	128
EQ	EQ003IS	250	440	395	533	485	417	367	230	187	298	27	137	128
EQ	EQ005IS	500	458	410	533	485	417	367	230	187	298	27	137	128
EQ	EQ010IS	1,000	525	465	598	535	433	403	245	188	332	31	154	142
EQS	EQS005IS	500	458	410	533	485	417	367	230	187	298	27	137	128
EQS	EQS010IS	1,000	525	465	598	535	433	403	245	188	332	31	154	142

Technical Data EQ / EQS

Basic	Type	Load capacity kg	Body size	Standard lifting height m	Lifting motor		Lifting speed, m / min			Load chain diameter mm	Chain falls	Classification FEM	Weight kg	Headroom C mm
					Output, kW	Rating, % ED	High (light load), 0 - 30%	High, 30 - 100%	Low					
EQ	EQ001IS	125	C	3	0.5	40 / 20	22.0	17.0	2.8	5.6 x 15.7	1	3m	32	395
EQ	EQ003IS	250	C	3	0.5	40 / 20	13.0	10.0	1.7	5.6 x 15.7	1	3m	31	395
EQ	EQ005IS	500	C	3	0.75	40 / 20	9.9	7.6	1.3	5.6 x 15.7	1	3m	32	410
EQ	EQ010IS	1,000	D	3	1.5	40 / 20	9.2	7.1	1.2	7.1 x 19.9	1	2m	42	465
EQS	EQS005IS	500	C	3	0.75	40 / 20	9.9*	7.6*	1.3	5.6 x 15.7	1	3m	33	410
EQS	EQS010IS	1,000	D	3	1.5	40 / 20	9.2**	5.1**	1.2	7.1 x 19.9	1	2m	43	465

*% of full load, EQS005 speed ratio 6:1. **EQS010 speed ratio 4:1, 1.8 times faster lifting speed when lifting less than 30% of full load.

ER2 SERIES ELECTRIC CHAIN HOIST SINGLE & DUAL SPEED WITH INVERTER

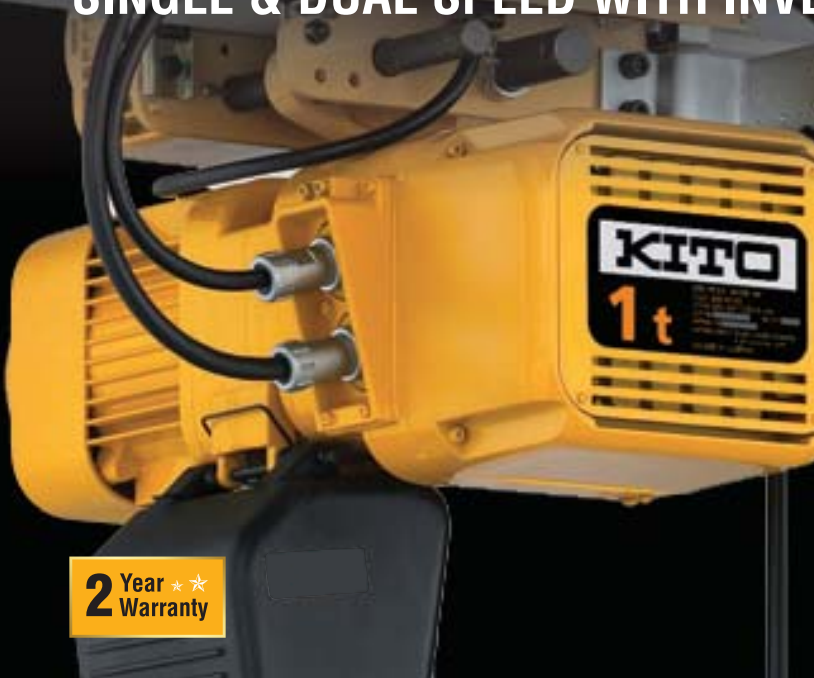

2 Year ★ ★
Warranty



Applications

- ✓ Mining, construction, engineering, entertainment
- ✓ Manufacturing, health care, food factory
- ✓ Engineered to perform in the industry's toughest jobs and most extreme situations

Features

- ✓ Available in capacities ranging from 250 kg to 20 tonnes in optional lift heights
- ✓ Also available up to 50 tonnes upon request
- ✓ Dual-speed inverter with adjustable speed
- ✓ Push button control designed with an emergency stop
- ✓ Patented Friction Clutch allows for reliable overload protection and safety
- ✓ Thermal Protection on hoist motor reduces the risk of motor burnout
- ✓ Upper/Lower Limit Switch
- ✓ Adjustment free brakes - less maintenance
- ✓ Nickel plated load chain - added resistance to rust and abrasion
- ✓ Fan cooled motor - reduces overheating
- ✓ Condition monitoring with Counter/Hour Meter – built-in

Australian Standard: AS 1418.2

A reliable and robust hoist ER2 Electric Chain Hoist is environmentally friendly with its new compact, lightweight and energy efficient design.

Capacity: 250kg – 20T

Options



Motorized trolley



Push trolley



Geared trolley

ER2 Series Electric Chain Hoist - Single Speed

Outline

Rated capacity:	Single speed – 250 kg to 20 t
Voltage:	380-415 V 50 Hz
Control voltage:	24 V
Duty rating:	Single speed – 60% ED (60 min.)
Classification:	M4, M5, M6 (ISO); 1 Am, 2m, 3m (FEM); H4 (ASME)
Motor insulation:	Class F for 380-415-50
Enclosure:	Hoist body – IP55, Push button control - IP 65
Suspension varieties:	Hook, manual trolley, motorized trolley
Operating temperature:	-20 to 40 °C (-4 to 104 °F)
Operating humidity:	85%RH or less

Specifications (Single Speed)

Capacity	Part No. (3 Metre)	Part No. (6 Metre)	Model	Lifting Speed m/min	Motor Rating output KW	Motor Rating (%ED)	Load Chain Dia (mm) x fall	Hook Suspended Headroom (mm)	Hook Suspended Weight (kg)	Load Chain Dia x Pitch (mm)	Load Chain Part No.
Single Speed											
250kg	45801	45961	ER2-003S	9.1	0.56	60	4.3 x 1	350	27	4.3x12.0	45951
500kg	45802	45962	ER2-005L	3.8	0.56	60	6.0 x 1	370	33	6.0x16.7	45952
500kg	45803	45963	ER2-005S	7.3	0.9	60	6.0 x 1	370	37	6.0x16.7	45952
1 tonne	45804	45964	ER2-010L	3.5	0.9	60	7.7 x 1	430	47	7.7x21.4	45953
1 tonne	45805	45965	ER2-010S	7.1	1.8	60	7.7 x 1	430	54	7.7x21.4	45953
1.5 tonne	45806	64121	ER2-015S	4.5	1.8	60	10.2 x 1	510	72	10.2x28.4	45954
2 tonne	45807	45966	ER2-020L	3.7	1.8	60	10.2 x 1	575	73	10.2x28.4	45954
2 tonne	45808	63453	ER2-020S	7.0	3.5	60	10.2 x 1	590	91	10.2x28.4	45954
2.5 tonne	45809	63550	ER2-025S	5.7	3.5	60	11.2 x 1	625	104	11.2x31.2	45955
3 tonne	45810	63130	ER2-030S	4.4	3.5	60	10.2 x 2	785	107	10.2x28.4	45954
5 tonne	45811	62866	ER2-050S	2.9	3.5	60	11.2 x 2	850	132	11.2x31.2	45955

*KITO PWB stock the above capacity hoists. Greater than 5T capacity is available on request. All hoists have optional lift heights available.

Type of containers

The containers are mounted via various connection methods; customized to the model of the hoist and/or the lifting height. In some cases they can be suspended from an additional trolley.

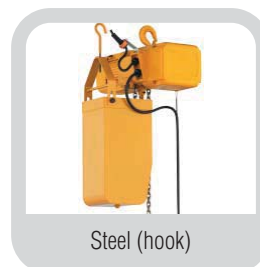
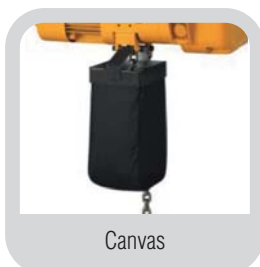

ER2 Series Electric Chain Hoist - Dual Speed

Outline

Rated capacity:	Dual speed – 250 kg to 10 t plus
Voltage:	380-415 V 50 Hz
Control voltage:	24 V
Duty rating:	Dual speed – 40/20% ED (30/10 min.)
Classification:	M4, M5, M6 (ISO); 1 Am, 2m, 3m (FEM); H4 (ASME)
Motor insulation:	Class F for 380-415-50
Enclosure:	Hoist body – IP55, Push button control - IP 65
Suspension varieties:	Hook, manual trolley, motorized trolley
Operating temperature:	-20 to 40 °C (-4 to 104 °F)
Operating humidity:	85%RH or less

Specifications (Dual Speed)

Capacity	Part No. (3 Metre)	Part No. (6 Metre)	Model	Lifting Speed m/min	Motor Rating output KW	Motor Rating (%ED)	Load Chain Dia (mm) x fall	Hook Suspended Headroom (mm)	Hook Suspended Weight (kg)	Load Chain Dia x Pitch (mm)	Load Chain Part No.
Dual Speed with Inverter											
250kg	45821	63302	ER2-003IS	10.8-1.8	0.56	40/20	4.3 x 1	350	27	4.3x12.0	45951
500kg	45822	62820	ER2-005IL	4.5-0.8	0.56	40/20	6.0 x 1	370	32	6.0x16.7	45952
500kg	45823	62846	ER2-005IS	8.5-1.4	0.9	40/20	6.0 x 1	370	36	6.0x16.7	45952
1 tonne	45824	62944	ER2-010IL	4.2-0.7	0.9	40/20	7.7 x 1	430	45	7.7x21.4	45953
1 tonne	45825	63325	ER2-010IS	8.2-1.4	1.8	40/20	7.7 x 1	430	52	7.7x21.4	45953
1.5 tonne	45826	63854	ER2-015IS	5.3-0.9	1.8	40/20	10.2 x 1	510	72	10.2x28.4	45954
2 tonne	45827	62951	ER2-020IL	4.3-0.7	1.8	40/20	10.2 x 1	575	73	10.2x28.4	45954
2 tonne	45828	64773	ER2-020IS	8.2-1.4	3.5	40/20	10.2 x 1	590	89	10.2x28.4	45954
2.5 tonne	45829	POA	ER2-025IS	6.6-1.1	3.5	40/20	11.2 x 1	625	100	11.2x31.2	45955
3 tonne	45830	63180	ER2-030IS	5.2-0.9	3.5	40/20	10.2 x 2	785	105	10.2x28.4	45954
5 tonne	45831	62813	ER2-050IS	3.3-0.6	3.5	40/20	11.2 x 2	850	128h	11.2x31.2	45955

*Optional lift heights available.

Applications



ER2 Series Electric Chain Hoist

Options

TROLLEYS

Motorized Trolley MR2



125kg to 20t

Push Trolley TSP



125kg to 3t



5t

Geared Trolley TSG



125kg to 3t



5t to 20t

➤ Motorized Trolley MR2

Bearing built-in side rollers provide smooth running through the minimum radius curve and excellent traversing performance with preventive derailment.

➤ Push & Geared Trolley

- Designed to provide smooth and easy traversing.
- Lugs provide protection from striking damage against rail stoppers, and from falling off the rail.
- Wheel flanges also prevent derailment.

➤ Push Trolley TSP

Designed for light load manual applications (125kg to 5t)

➤ Geared Trolley TSG

Designed for precise positioning and traversing by using hand chain (125kg to 20t)

SILICONE PENDANT COVER



Part No.	Model	Capacity (kg)	Traverse Speed M/Min	Beam Range (mm)	Min Radius (Mtr)
Single speed standard flange width					
45901	MR2-010S	1000	20	58 - 153 Flg	0.8
45902	MR2-020S	2000	20	82 - 178 Flg	0.8
45903	MR2-030S	3000	20	82 - 178 Flg	1.0
45904	MR2-050S	5000	20	100 - 178 Flg	1.8
Dual speed standard flange width					
45921	MR2-010IS	1000	24/4	58 - 153 Flg	0.8
45922	MR2-020IS	2000	24/4	82 - 178 Flg	0.8
45924	MR2-030IS	3000	24/4	82 - 178 Flg	1.0
45925	MR2-050IS	5000	24/4	100 - 178 Flg	1.8
Single speed wide flange					
45911	MR2-010SW	1000	20	154 - 305 Flg	0.8
45912	MR2-020SW	2000	20	179 - 305 Flg	0.8
45913	MR2-030SW	3000	20	179 - 305 Flg	1.0
45914	MR2-050SW	5000	20	179 - 305 Flg	1.8
Dual speed wide flange					
45931	MR2-010ISW	1000	24/4	154 - 305 Flg	0.8
45932	MR2-020ISW	2000	24/4	179 - 305 Flg	0.8
45933	MR2-030ISW	3000	24/4	179 - 305 Flg	1.0
45935	MR2-050ISW	5000	24/4	179 - 305 Flg	1.8
Silicone pendant cover					
67134	3 PUSH BUTTON COVER ASSEMBLY(HOIST ONLY)				
67135	5 PUSH BUTTON COVER ASSEMBLY(HOIST & MOTOR TROLLEY)				

KITOPWB

Premium Quality Products

For more information:

Call 1300 792 262

Visit www.kitopwb.com.au

Head Office

441 Grimshaw Street,
Bundoora, VIC 3083

Tel: 1300 792 262 Fax: 03 9467 7290

Email: vicsales@kitopwb.com.au

QLD Office

1/119 Bandarra Street,
Richlands, QLD 4077

Tel: 07 3375 1288

Email: qldsales@kitopwb.com.au

WA Office

2/11 Mallaig Way,
Canning Vale, WA 6155

Tel: 08 9256 2499

Email: wasaless@kitopwb.com.au

ER2 Series Electric Chain Hoist

Specialised Options

> CDER2

Cylinder Control Dual/Single Speed
with Hook Suspension

- Standard length of power supply cable is five meters.
- Length of lift, push button cord and power supply cable is standard only available.
- Extending the load chain is prohibited with additional links.
- Plastic chain container is provided only.

Capacities: 125kg, 250kg (Single speed & dual speed)

Suspension: Hook suspended only



> ER2

Large Capacity

- Standard length of power supply cable is ten meters.
- Optional length of lift, push button cord and power supply cable besides standard is available on your request.
- Extending the load chain is prohibited with additional links.
- Steel chain containers are available as option as shown in Section of "Chain Containers" if your lift is more than capacity of the standard container volume.

Capacities: 7.5T, 10T, 15T, 20T

Suspension: Hook suspended, or with motorized or geared trolley



> TWER2

Twin Hook

- KITO Twin Hook electric chain hoist, which is equipped with a single motor and two hooks, is intended to lift the hooks horizontally, equally and safely.
- This product is the most suitable for lifting applications requiring two lifting points for a wide load or retaining a level lifting.
- For special requirements such as dual speed or curve beam, available on request.

Capacities: 125kg + 125kg, 250kg + 250kg, 500kg + 500kg, 1T + 1T, 1.5T + 1.5T, 2.5T + 2.5T (Single speed)

Suspension: Motorized or manual trolley on hoist, or hook suspended



ER2 Series Electric Chain Hoist

Specialised Options

> ER2 WIND

Wind Hoist

KITO ER2 electric chain hoist is a reliable and robust device which is used for all demanding applications such as wind turbines.

- 3 phase/ 400V operating voltage.
- Optional operating voltage, length of lift and classification besides standard is available on your request.
- With options for radio remote control, foam hook protector and plain, geared or motorised trolley.
- Load sheave is 5 or 6 pockets (depending on the product model) for very smooth operation.
- Up to 150m HoL as standard.

Capacities: Standard 800kg fixed* (Single speed)

*Higher load capacities upon request

Suspension: Hook suspended, or with push, geared or motorized trolley



> FER2

Food Grade

with Hook Suspension

KITO PWB's Food Grade ER2 Electric Chain Hoist is well-suited for lifting applications in food, beverage, and pharmaceutical processing industries where pristine cleanliness is critical.

- Food grade lubricants used on the load chain and in the gearbox are NSF H1 compliant for safe use in any facility where incidental contact with product is a concern.
- Customer specified options include white epoxy paint, stainless steel and nickel-plated hardware, and nickel-plated load chain making this hoist well-suited for contaminant controlled or corrosive processing environments.

Capacities: 500kg, 1T, 2T (Single speed or dual speed)

Suspension: Hook suspended, or with push, geared or motorized trolley



> SHER2

Ultra Low Headroom

When height becomes an issue – the KITO Electric Chain Hoist SHER2M for low ceiling heights.

- In situations where every centimetre of headroom is vital, the KITO Electric Chain Hoist SHER2M (Short Headroom ER2 Motorised Trolley Type) is a welcome solution.
- Apart from use in buildings with low ceilings, it is also ideal where considerable lifting heights are necessary. This is accomplished by means of a special KITO chain guide.

Capacities: 250kg, 500kg, 1T, 1.5T, 2T, 3T, 5T (Single speed)

Suspension: Push, geared or motorized trolley



EDL SERIES ELECTRIC CHAIN HOIST SINGLE & DUAL SPEED - PENDANT CONTROL



Applications

- ✔ Used in construction, engineering, manufacturing, wind towers
- ✔ Ideal for the assembly line, work station

Features

- ✔ This compact single phase Electric Hoist available in single or dual speed, is ideal for lifting small loads that are too heavy to be handled manually.
- ✔ The EDL range of single phase hoists from KITO feature heavy duty motors with automatic load brake and overload clutch, an IP54 rated lightweight compact aluminium body.
- ✔ 30% ED rating.
- ✔ Patented 'Friction Clutch' allows for reliable overload protection and safety.
- ✔ Upper Limit Switch.
- ✔ Motor has high performance mechanical brake for safe stopping.
- ✔ Nickel plated load chain allows for added resistance to rust and wear.

Light-weight, high-speed lifting with the flexibility of variable speeds. ED hoists are small enough to be portable, easily serviceable and provide industry-leading quality.

Capacity: 100 – 480kg

Options



Push Trolley
(for max. 480kg)



Mini Trolley TMH25
(for 60 - 240kg)
Part No. 48350

EDL Series Electric Chain Hoist - Single & Dual Speed

Outline

Rated capacity:	100kg to 480kg
Voltage:	240V 50Hz
Control voltage:	Low voltage control is standard
Motor insulation:	Class F
Enclosure:	Single speed/ Dual speed - IP54 (dust proof and water protected) IP65 Pendant
Suspension varieties:	Hook, universal trolley, manual trolley
Operating temperature:	-20 to 40°C
Operating humidity:	85% RH or less

Specifications

EDL Single Speed Pendant Control

Capacity	Part No.	Model	Standard Lift (m)	Lift Speed (m/min)	Headroom (mm)	Load Chain dia (mm) x falls	Weight (kg)	Load Chain Dia x Pitch (mm)	Load Chain Part No.
100kg	45398	EDL10S	3.0	13.0	315	4.0 x 1	12	4.0x12.0	48351
160kg	48347	EDL16S	3.0	20.0	330	4.0 x 1	16	4.0x12.0	48351
180kg	45399	EDL18S	3.0	8.0	315	4.0 x 1	12	4.0x12.0	48351
240kg	48348	EDL24S	3.0	13.5	330	4.0 x 1	16	4.0x12.0	48351
480kg	62445	EDL48S	3.0	6.7	520	4.0 x 2	21.5	4.0x12.0	48351

*Optional lift heights available.

EDL Dual Speed Pendant Control

Capacity	Part No.	Model	Standard Lift (m)	Lift Speed (m/min)	Headroom (mm)	Load Chain dia (mm) x falls	Weight (kg)	Load Chain Dia x Pitch (mm)	Load Chain Part No.
100kg	45400	EDL10ST	3.0	13.0/3.0	315	4.0 x 1	12.5	4.0x12.0	48351
160kg	44282	EDL16ST	3.0	20.0/5.0	330	4.0 x 1	16.5	4.0x12.0	48351
180kg	45401	EDL18ST	3.0	8.0/3.0	315	4.0 x 1	12.5	4.0x12.0	48351
240kg	48349	EDL24ST	3.0	13.5/3.0	330	4.1 x 1	16.5	4.0x12.0	48351
480kg	63624	EDL48ST	3.0	6.7/2.0	520	4.0 x 2	21.5	4.0x12.0	48351

*Optional lift heights available.

KITOPWB

Premium Quality Products

For more information:

Call 1300 792 262

Visit www.kitopwb.com.au

Head Office

441 Grimshaw Street,
Bundoora, VIC 3083

Tel: 1300 792 262 Fax: 03 9467 7290

Email: vicsales@kitopwb.com.au

QLD Office

1/119 Bandarra Street,
Richlands, QLD 4077

Tel: 07 3375 1288

Email: qldsales@kitopwb.com.au

WA Office

2/11 Mallaig Way,
Canning Vale, WA 6155

Tel: 08 9256 2499

Email: wasaless@kitopwb.com.au

EDCL SERIES ELECTRIC CHAIN HOIST DUAL SPEED - CYLINDER CONTROL



Applications

- ✔ Used in construction, engineering, manufacturing, fabrication
- ✔ Ideal for the assembly line, work station

Features

- ✔ This compact single phase Electric Hoist available in single or dual speed, is ideal for lifting small loads that are too heavy to be handled manually.
- ✔ Cylinder control provides the operator with at-hook control at the lifting point.
- ✔ The EDL range of single phase hoists from KITO feature heavy duty motors with automatic load brake and overload clutch, an IP54 rated lightweight compact aluminium body.
- ✔ 30% ED rating.
- ✔ Patented 'Friction Clutch' allows for reliable overload protection and safety.
- ✔ Upper Limit Switch.
- ✔ Motor has high performance mechanical brake for safe stopping.
- ✔ Nickel plated load chain allows for added resistance to rust and wear.

Light-weight, high-speed lifting with the flexibility of variable speeds. ED hoists are small enough to be portable, easily serviceable and provide industry-leading quality.

Capacity: 100 – 240kg

Options



Push Trolley
(for max. 480kg)



Mini Trolley TMH25
(for 60 - 240kg)
Part No. 48350

EDCL Series Electric Chain Hoist - Dual Speed

Outline

Rated capacity:	100kg to 240kg
Voltage:	240V 50Hz
Control voltage:	Low voltage control is standard
Motor insulation:	Class F
Enclosure:	Dual speed - IP54 (dust proof and water protected) Cylinder - IP44
Suspension varieties:	Hook, universal trolley, manual trolley
Operating temperature:	-20 to 40°C
Operating humidity:	85% RH or less

Specifications

Capacity	Part No.	Model	Standard Lift (m)	Lift Speed (m/min)	Headroom (mm)	Load Chain dia (mm) x falls	Weight (kg)	Load Chain Dia x Pitch (mm)	Load Chain Part No.
100kg	45402	EDCL10SD	1.8	13.0/3.0	945	4.0 x 1	15	4.0x12.0	48351
240kg	44209	EDCL24SD	1.8	13.5/3.0	960	4.0 x 1	19	4.0x12.0	48351

Applications



KITOPWB

Premium Quality Products

For more information:

Call 1300 792 262

Visit www.kitopwb.com.au

Head Office

441 Grimshaw Street,
Bundoora, VIC 3083

Tel: 1300 792 262 Fax: 03 9467 7290

Email: vicsales@kitopwb.com.au

QLD Office

1/119 Bandarra Street,
Richlands, QLD 4077

Tel: 07 3375 1288

Email: qldsales@kitopwb.com.au

WA Office

2/11 Mallaig Way,
Canning Vale, WA 6155

Tel: 08 9256 2499

Email: wasaless@kitopwb.com.au

EHL SERIES CHAIN AIR HOIST



Applications

- ✓ Used in mining, oil and gas, petrochem, fertilizer, offshore
- ✓ Ideal for applications where powered hoists are not permitted eg. explosive environments

Features

- ✓ Compact and lightweight ensures ease of handling.
- ✓ Operation speed depends on the amount of pressure applied to the push buttons or how hard the control rope is pulled.
- ✓ Installation – simply connect to your plants compressed air system.
- ✓ Precise variable lifting and high speed.
- ✓ Quality load chain allowing high frequency of use.
- ✓ Upper and lower limit switches.
- ✓ EHL Air Hoists from Endo Kogyo are fitted with rotary vane motors in strong lightweight aluminium bodies, for easy handling in a variety of industrial and construction applications.
- ✓ Variable speed models available in either cord or pendant controls with optional lift heights.

Australian Standard: AS 1418.2

Small and compact body provides easy handling. Unique feature of being able to be used in explosive environments.

Capacity: 125kg – 6T

Options



MTH Series Air Trolley
In conjunction with the EHL Air Hoist

EHL Series Chain Air Hoist

➤ EHL Series Chain Air Hoist



Capacity	Part No. 3 Metre (Pendant)	Part No. 3 Metre (Pull Cord)	Model	Lift Speed (m/ min)	Load Chain Dia (mm) x fall	Headroom (mm)	Weight (kg)	Load Chain Dia x Pitch (mm)	Load Chain Part No.
125kg	44519	NA	AT125K	14.5	4.0 x 1	410	12.5	4x12	48351
500kg	49251	49250	EHL05TS	10.5	6.3 x 1	365	19	6.3x19	43206
1 tonne	49253	49252	EHL1TW	5.2	6.3 x 2	440	25	6.3x19	43206
1 tonne	63538	48237	EHL1TS	6.0	7.1 x 1	480	34	7.1x21	46745
2 tonne	48238	48239	EHL2TW	3.0	7.1 x 2	540	42	7.1x21	46745
3 tonne	44181	44998	EHL3TS	3.0	12.5 x 1	585	75	12.5x38	46752
6 tonne	47609	45000	EHL6TW	1.5	12.5 x 2	770	96	12.5x38	46752

*Optional lift heights available.

➤ MTH Series Air Trolley

- Used in conjunction with the EHL Air Trolley
- Designed for easy handling and high speed performance
- Available in pendant control with 2 directional functions



Capacity	Part No.	Model	Travel Speed (m/min)	Beam Range (mm)	Min Beam Radius (mm)	Control Type	Weight (kg)
Standard Flange Width							
1 tonne	44610	MTH-1T	28.0	75-125	800	Pendant	35.0
2 tonne	44611	MTH-2T	18.0	125-150	1000	Pendant	63.0
6 tonne	44612	MTH-6.3T	19.0	150-190	2500	Pendant	127.0
Wide Beam Flange Width							
1 tonne	TBA	MTH-1T	28.0	154-305	800	Pendant	35.0
2 tonne	TBA	MTH-2T	18.0	154-305	1000	Pendant	63.0
6 tonne	TBA	MTH-6.3T	19.0	154-305	2500	Pendant	127.0

➤ EHW Series Wire Rope Air Hoist

- Designed for Wire Rope lift, the ENDO EHW Air Hoist is available in hook or pendant control with a cone brake system.
- Heat treated planetary reduction gears are small and lightweight and can take a large speed reduction ratio.



Capacity	Part No.	Model	Standard Lift (m)	Lift Speed (m/min)	Headroom Hook Suspended (mm)	Control Type	Weight (kg)
120kg	44992	EHW-120	1.9	16.0	680	On Hook	9.5
120kg	44993	EHW-120R	1.9	16.0	630	Pendant	9.7
250kg	44182	AH-250R	2.5	11.0	745	Pendant	18.2

KITOPWB

Premium Quality Products

For more information:

Call 1300 792 262

Visit www.kitopwb.com.au

Head Office

441 Grimshaw Street,
Bundoora, VIC 3083

Tel: 1300 792 262 Fax: 03 9467 7290

Email: vicsales@kitopwb.com.au

QLD Office

1/119 Bandarra Street,
Richlands, QLD 4077

Tel: 07 3375 1288

Email: qldsales@kitopwb.com.au

WA Office

2/11 Mallaig Way,
Canning Vale, WA 6155

Tel: 08 9256 2499

Email: wasaless@kitopwb.com.au

CM LODESTAR ELECTRIC HOIST

415v – 50Hz



Features

- ✔ Designed and manufactured by Columbus McKinnon USA.
- ✔ Overload protection helps prevent lifting of dangerous overloads.
- ✔ Units are not oil lubricated – no risk of oil on stage.
- ✔ 24v control voltage.
- ✔ Durable and lightweight housing. Cast aluminium, black powder coated finish for low visibility.
- ✔ Heavy duty DC brake.
- ✔ Helical design for long wear life and smooth operation.
- ✔ Zinc plated to protect against corrosion.
- ✔ Black phosphate finish optional.
- ✔ Supplied in a black powder coat finish and are available in a range of capacities that can be chained up to your specific lift requirements.

The range of CM entertainment hoists from KITO PWB® are easy to handle, operate and maintain. Protected by a lifetime warranty and designed for versatile operation in the inverted position.

(Conditions applied to the lifetime warranty)

Capacity: 500kg - 2T

Optional Features include:

- Chain bag – easy to mount cloth type bags.
- Chain stop – mounted on load chain to prevent over-travel.

Capacity	Part No.	Model	Lift Speed (m/min)	No. of Chains	Load Chain Dia (mm) x fall	Headroom (mm)	Load Chain Dia x Pitch (mm)	Load Chain Part No.
500kg	47112	F	4	1	6.3 x 1	413	6.3 x 19	43746
1 tonne	47113	L	4	1	7.9 x 1	472	7.9 x 21.8	46747
2 tonne	47114	RR	2	2	7.9 x 2	613	7.9x21.8	46747

Entertainment Clamps

- ✔ Load pin incorporated for load suspension with reduced headroom.
- ✔ Working load limit up to 1 tonne.
- ✔ Designed to fit flanges of most structural beams.
- ✔ Low visibility, black powder coat finish and simple to install.
- ✔ Suitable for use with powered hoists such as CM Lodestars or Chain Blocks.

Australian Standard: AS 1418.2



Capacity	Part No.	Beam Range (mm)	Headroom (min/mm)	Headroom (max/mm)	Suspension	Weight (kg)
1 tonne	45785	65-230	78	135	20.3	4.8

Entertainment Shackles

- ✔ These shackles represent an easy and effective way of providing a connection of chain, wire rope or other rigging equipment.
- ✔ Supplied in a black powder coat finish.

Australian Standard: AS 2741



Size (mm)	WLL (tonnes)	Part No.	d (mm)	D (mm)	W (mm)	L (mm)	B (mm)	e (mm)
13	2.0	41794	13	16	21	48	33	33
16	3.25	41795	16	20	27	61	43	40
19	4.75	41796	19	22	32	72	51	48

KITOPWB

Premium Quality Products

For more information:

Call 1300 792 262

Visit www.kitopwb.com.au

Head Office

441 Grimshaw Street,
Bundoora, VIC 3083

Tel: 1300 792 262 Fax: 03 9467 7290

Email: vicsales@kitopwb.com.au

QLD Office

1/119 Bandarra Street,
Richlands, QLD 4077

Tel: 07 3375 1288

Email: qldsales@kitopwb.com.au

WA Office

2/11 Mallaig Way,
Canning Vale, WA 6155

Tel: 08 9256 2499

Email: wasaes@kitopwb.com.au

RY SERIES WIRE ROPE HOIST

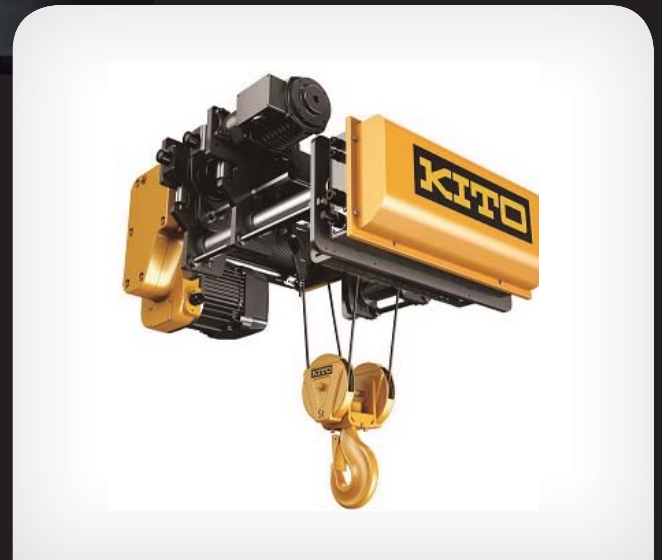

Applications

- ✓ Mining, construction, engineering, warehousing, manufacturing
- ✓ Ideal for the assembly lines, work stations, job sites, and more

Features

- ✓ VFD dual-speed control for hoist and trolley.
- ✓ Low-load high-speed function.
- ✓ Electronic overload limiter.
- ✓ Electronic thermal motor protection.
- ✓ Easily accessible condition monitoring via hour meter and operation counter.
- ✓ Premium wire rope (IWRC high-strength wire rope).
- ✓ Externally adjustable upper/lower limit switches.
- ✓ High-performance motor brakes come maintenance-free for up to 1 million starts.
- ✓ Full 360° high-strength rope guide.
- ✓ Guide rollers and rubber trolley bumpers.

Australian Standard: AS 1418

Designed specifically for safety, reliability and performance, these M5 rated hoists are loaded with revolutionary features and benefits for high demand applications.

Capacity: 5t & 10t

RY Series Wire Rope Hoist



Outline

Rated capacity:	5t and 10t
Voltage:	415-3-50
Control voltage:	24V
Classification:	ISO M5
Lifting heights:	5t – 7.6m & 10.2m 10t – 9m & 12m
Lifting speeds:	5t – 5.0~0.8 m/min 10t – 8.0~1.3 m/min 5t & 10t – 6.0~1.0 m/min
Flange width range:	5t – 125mm to 350mm 10t – 150mm to 350mm 5t & 10t – 351mm to 500mm
Intermittent rating:	40/20 % ED
Short time rating:	60 min
Enclosure:	Hoist/ Trolley – IP44
Operating temperature:	-20 to 40°C
Mounting:	Ultra-low headroom
Wheels:	Will operate on a tapered or flat beam flange

Specifications

Capacity (t)	Part No.	Code	Lift (m)	Flange width (mm)	Inverter for lifting			Inverter for traversing		Weight*	
					Motor output (kW)	Speed when loaded: High speed to low speed (m/min)	Speed during low loading (m/min)	Motor output (kW)	Speed (m/min)	Main unit (kg)	Hook (kg)
5	48860	RYLB050ISIS0735	7.6	125 to 350	5.0	5.0 to 0.8	7.5	0.4	20 to 3.3	440	35
	48861	RYLB050ISIS0750		351 to 500						445	
	48862	RYLB050IHIS0735		125 to 350	8.0	8.0 to 1.3	12.0			460	
	48863	RYLB050IHIS0750		351 to 500						465	
	48864	RYLB050ISIS1035	10.2	125 to 350	5.0	5.0 to 0.8	7.5			475	
	48865	RYLB050ISIS1050		351 to 500						480	
	48866	RYLB050IHIS1035		125 to 350	8.0	8.0 to 1.3	12.0			495	
	48867	RYLB050IHIS1050		351 to 500						500	
10	48868	RYLC100ISIS0935	9	150 to 350	13.2	6.0 to 1.0	9.0	0.75	20 to 3.3	1015	90
	48869	RYLC100ISIS0950		351 to 500						1025	
	48870	RYLC100ISIS1235	12	150 to 350						1090	
	48871	RYLC100ISIS1250		351 to 500						1100	

* Weight: The weight of the main unit includes the weight of the hook.

KITOPWB

Premium Quality Products

For more information:

Call 1300 792 262

Visit www.kitopwb.com.au

Head Office

441 Grimshaw Street,
Bundoora, VIC 3083

Tel: 1300 792 262 Fax: 03 9467 7290

Email: vic-sales@kitopwb.com.au

QLD Office

1/119 Bandarra Street,
Richlands, QLD 4077

Tel: 07 3375 1288

Email: qld-sales@kitopwb.com.au

WA Office

2/11 Mallaig Way,
Canning Vale, WA 6155

Tel: 08 9256 2499

Email: wasales@kitopwb.com.au